

ELEVATION
ASP6 & PUMP SUMP

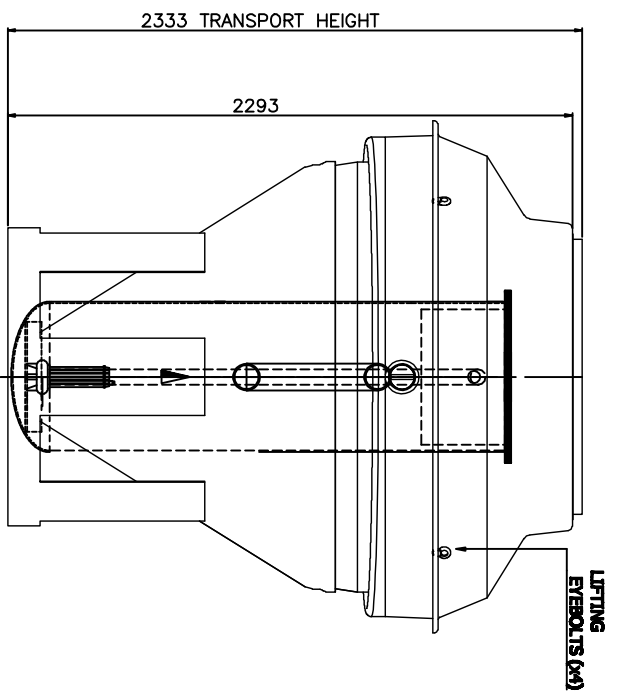

END VIEW
ASP6 & PUMP SUMP

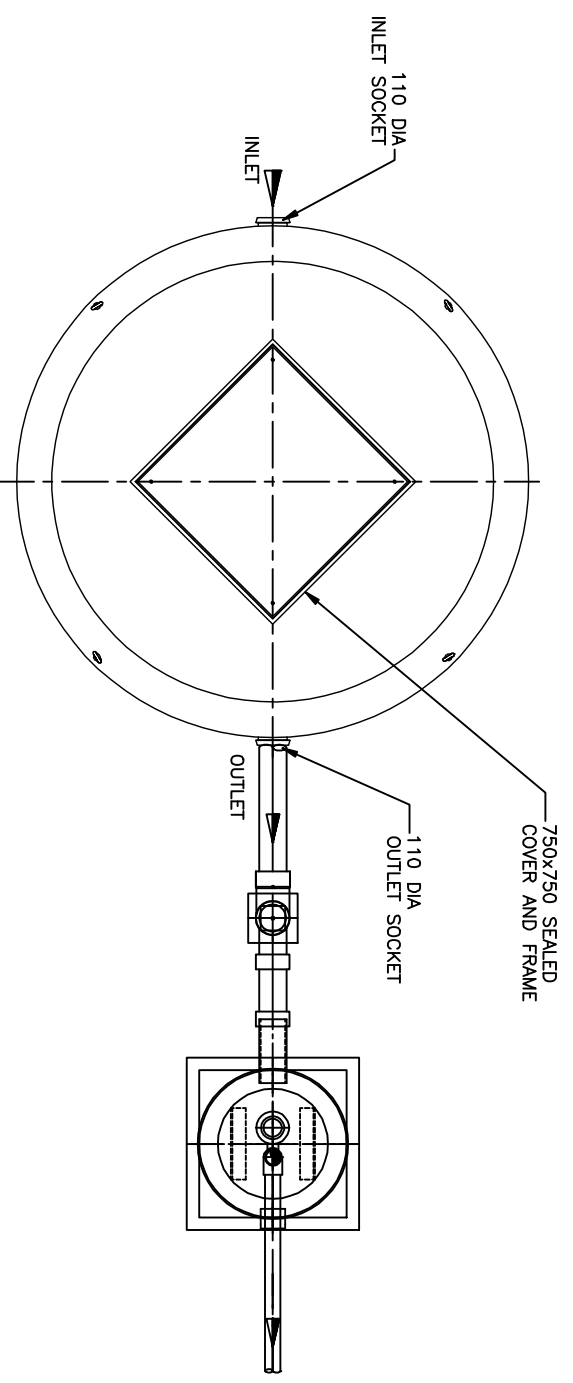

PLAN
ASP6 & PUMP SUMP

REV.	DATE	BY	CHKD.	RP	ISSUED FOR INFORMATION	DESCRIPTION
1	23.03.09	SL	TB	RP	ISSUED FOR INFORMATION	THIS DRAWING IS THE PROPERTY OF CONDER SOLUTIONS Ltd. AND IS NOT TO BE COPIED IN PART OR WHOLE WITHOUT WRITTEN PERMISSION
A3	DO NOT SCALE IF IN DOUBT ASK ALL DIMENSIONS IN MM		GENERAL TOLERANCES (unless noted otherwise)	GRIP FABRICATED MACHINED	LINEAR	± 5mm ± 2mm ± 0.5mm
			ANGLE			± 0.5° ± 0.2° ± 0.1°

IMPORTANT INVERT LEVEL NOTE
The inlet to ASP shown on this drawing is dependant on the invert level of raw sewage coming from the dwelling unless otherwise stated. Therefore the Ground Level is SITE SPECIFIC shown GL @ 0.000m on drawing. Additional extension pieces or risers may be required at extra cost.

IMPORTANT INVERT LEVEL NOTE (RIBBED TANKS ONLY):
The inlet and outlet Invert Level(IL) shown on this drawing is to internals of the shell unless otherwise stated. For Invert level to the outside of the shell ribs, see the conversion below:
Ø1.0m, 1.2m, 1.5m, 1.8m, 2.5m IL+50mm ('X')
Ø3.0m, 4.0m IL +75mm ('X')

TANKS SUPPLIED WITH LOOSE SHAFTS DO NOT COME SUPPLIED WITH A FIXING KIT.
THIS IS THE RESPONSIBILITY OF THE SITE CONTRACTOR.

INNER TANK SHELL
DETAIL 'X'

conder
ENVIRONMENTAL SOLUTIONS

conder
ENVIRONMENTAL SOLUTIONS

TITLE
ASP06 SEWAGE TREATMENT PLANT
WITH PUMP SUMP

1ST ANGLE PROJECTION

DRAWN BY	CHKD.	APPD.	SCALE	DRAWING No.	REVISION
SL	TB	RP	NTS	ASP06 SALES	1
DATE	DATE	DATE			
04.08.09	04.08.09	23.03.09			